

COOK'S CONSTRUCTION &
CONSULTING, INC

WHY CHOOSE COOK'S FOR MODULAR INTERIORS?

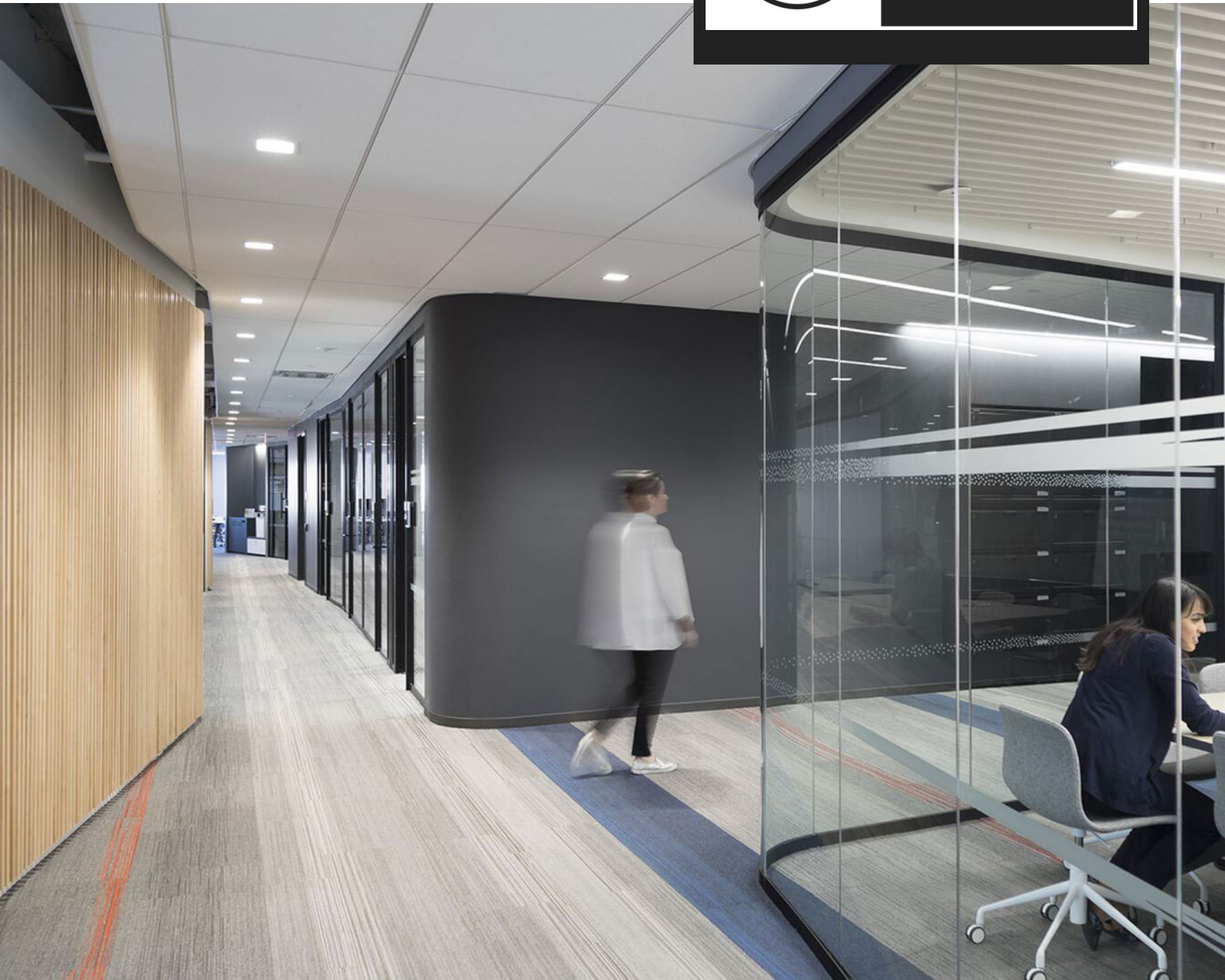

COOK'S
CONSTRUCTION & CONSULTING



THE TEAM

The Cook's Construction team has spent a combined 60+ years working with raised access floors, demountable partitions, operable partitions & roller shades. Cook's has successfully executed millions of square feet worth of raised access flooring across Canada. Some of the most notable raised access flooring installations in Canada has had the Cook's team involved!



Russell J. Cook GSC, Dip.ME - President

15 years of raised access flooring experience across Western Canada, working on such notable projects as, The BOW Tower, Imperial Oil, LNG Canada and the University of Calgary.

John Mackenzie, P.Eng - Senior Vice President

Over 30 years of experience working with the design, engineering and implementation of raised access flooring projects across Canada. Working on such projects as, Telus Gardens, The BOW Tower, U of BC and many more.

Coby Huether - Construction Manager

Over 15 years of raised access flooring experience across Western Canada, working along side Russell J. Cook on The Bower Tower, Imperial Oil and so much more.

Keith Smith, PMP - Senior Project Manager

Seasoned project manager with over 20 years of commercial construction experience across Western Canada!

THE INTERIOR MODULAR SYSTEM

THE COOK'S GUARANTEE

Here at Cook's Construction & Consulting we pride ourselves on quality, from our dedication & passion and our partnerships with world leading manufacturers, coupled with our IN-HOUSE certified team of trained professionals we are able to offer the best of both quality and service! Offering multiple scopes, Cook's will work with the general contractor, design team, engineers and other project members to ensure a smooth project that is on time and on budget. Cook's uses our own forces for every scope, we do not sub-contract any element of work including shop drawings, estimating, project management and of course installations. You can trust us with your project!

The Cook's Construction team is committed to making the interior environment better for the occupants through the use of modular systems such as, raised access flooring, demountable & operable partitions and of course roller/solar shading. These modular interior systems work together to provide flexibility, comfort and provide a space that will adapt as the needs of the occupants does.

Our process starts with the raised access floor system, this provides the level base that can distribute the power, data, mechanical and any other infrastructure. This level surface is perfectly suited for the demountable glass partitions, allowing for a truly demountable system no matter where on the floor plate they are installed.

Operable and folding walls help in dividing off rooms and allowing the occupants to reconfigure their spaces with ease - this coupled with the raised access floor and modular power distribution means that all the connectivity is within the raised floor, allowing you to divide rooms and maintain connections.

Completing the modular interior systems are the roller shades, the ability to mitigate heat load and glare by either manual or motorized blinds makes any space more comfortable.

FOCUS ON SUSTAINABILITY

ASP Access floors are a leading global company in the access floor industry, revolutionizing access flooring systems! ASP has recently launched their "walk carbon neutral" program, ASP has undertaken life-cycle assessments and have obtained full EPDs on the Urban and Icon series panels systems!



Partnering with EKOS, ASP and Cook's are now able to offer our clients the option to select carbon neutral access flooring for their projects!

We offset the carbon footprint of our access floor system with certified carbon credits. The certified credits are sourced from projects that grow and protect rainforest around the world.

ASP and Cook's have enlisted local Canadian initiatives and are working hard to partner with indigenous leaders in Canada to offer a similar carbon offset right here in Canada!

Our clients can opt to certify their ASP Floor products for their project as either:

- **Zero Carbon Certification** where 100% of the products emissions are offset, or
- **Climate Positive Certification** where 120% of the products emissions are offset.



Product



Product

PATENTED DESIGNS

RAISED ACCESS FLOORS MANUFACTURED BY ASP ACCESS FLOORS

The ASP panel systems have revolutionized the access floor industry with their commitment to research & development and patented designs. From the expansion joints built into the ICON series pedestals, to the "walk carbon neutral" program, showcases the ingenuity and the sustainability of the systems.

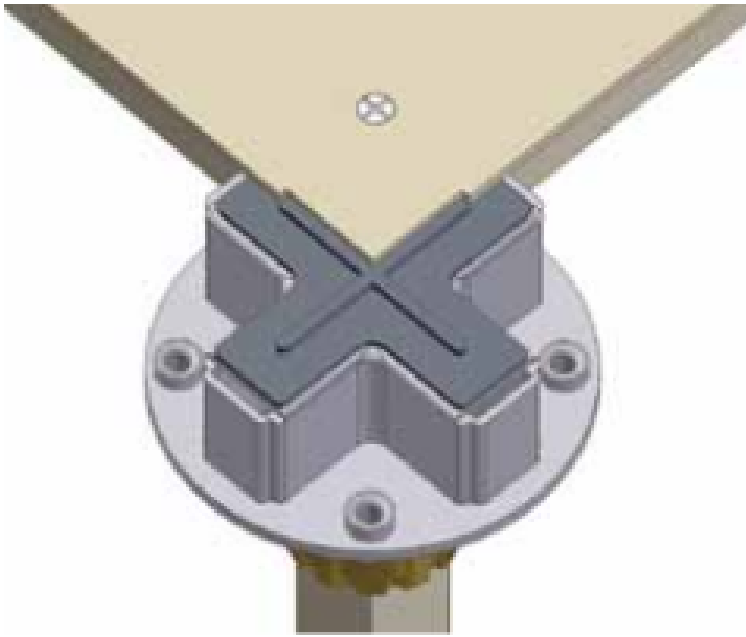

The built-in expansion joint and panel cut-out: is designed to keep the panels separated by 0.3mm at all times. This eliminates the the panels clicking or rubbing up against each other. Noise and sound from an underfoot feel has always been a contentious issue with raised access floors. The ASP patented designs have eliminated the issues making for a solid underfoot feel and making it feel like you're walking on a standard concrete deck.

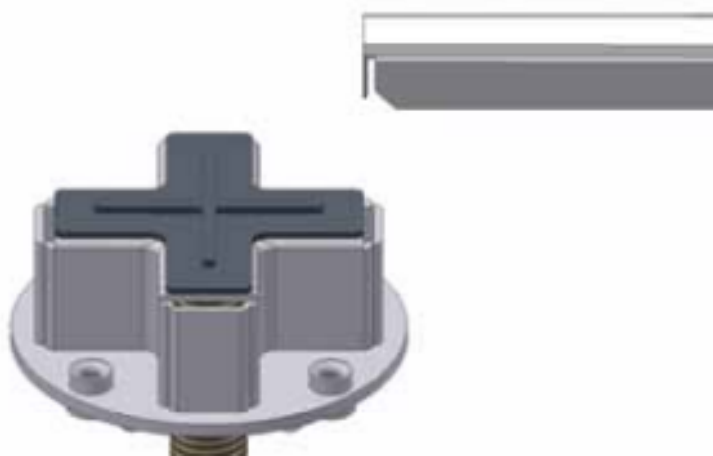

The ASP **Air-tight system** is a system that specifically designed to minimize air leakage for the the system is used with a UFAD setting. The system incorporates the use of a clip on air tight stringer that acts as a barrier in between the panels to eliminate air leakage.

DEMOUNTABLE PARTITIONS

MANUFACTURED IN CANADA BY MURAFLEX

Muraflex transforms floor plans into architectural spaces. With a European touch, our design-savvy demountable glass office wall systems and freestanding pods create a distinguished work environment, bringing elegance and purpose together. Rather than permanent drywall, benefit from safe, flexible and reconfigurable walls through one of our 7 lines: MIMO, FINO and QUADRO our demountable glass partitions, EXPO our telescoping door, the versatile demising wall system PLANIKA, and finally two freestanding pods: ARCO and ZITTO.

MIMO is a **true demountable wall**. Installed on the finished floor, MIMO can easily be moved and reconfigured. This line satisfies all types of walls, glass or solid panels, and doors: sliding; hinged; with pivots; glass or wood. MIMO walls can also accommodate electrical wiring or plumbing. Apart from being stylish and sophisticated, this line is functional, fully customizable, and perfectly hygienic.



MIMO is a perfect option for all commercial designs, such as offices, public spaces, or sanitary needs such as hospitals or laboratories. Made from fully recyclable aluminum, the extrusions are available in countless colors and finishes and can accept a variety of glass and wall panels. Our MIMO range has all the required and necessary conformities, compliances, tests, certifications and contributes to the LEED and WELL codes.

ROLLER SHADES

MANUFACTURED BY ROLL-A-SHADE

Roll-A-Shade® has been manufacturing, installing, and servicing window shades for 35 years. Our superior reputation spans throughout the restaurant, convenience, financial, grocery, hospitality, retail, and more.

Our complete one-stop service capability, from the initial visit to obtain measurements, fabrication requirements, to the manufacturing, testing, and professional installation, guarantees that you receive the highest quality product with the utmost reliability. We work directly with architects, contractors, facility departments, and independent owners to manufacture custom roller shades. Our manufacturing facility allows us to produce shades rapidly when necessary for those last-minute rush jobs.

All our window treatments are thoroughly tested and professionally installed by fully insured contractors. We offer a 10-year warranty on fabric and a lifetime warranty on most parts. We ship and install throughout North America. So, we can accommodate your needs with a quality Roll-A-Shade® product regardless of your location. We also provide full facility maintenance support for all window treatments, including those from other manufacturers.

Roll-A-Shade® is committed to providing the highest quality window treatment solutions through our skilled and dedicated employees, state-of-the-art manufacturing process, nationwide installation service, and facility support.

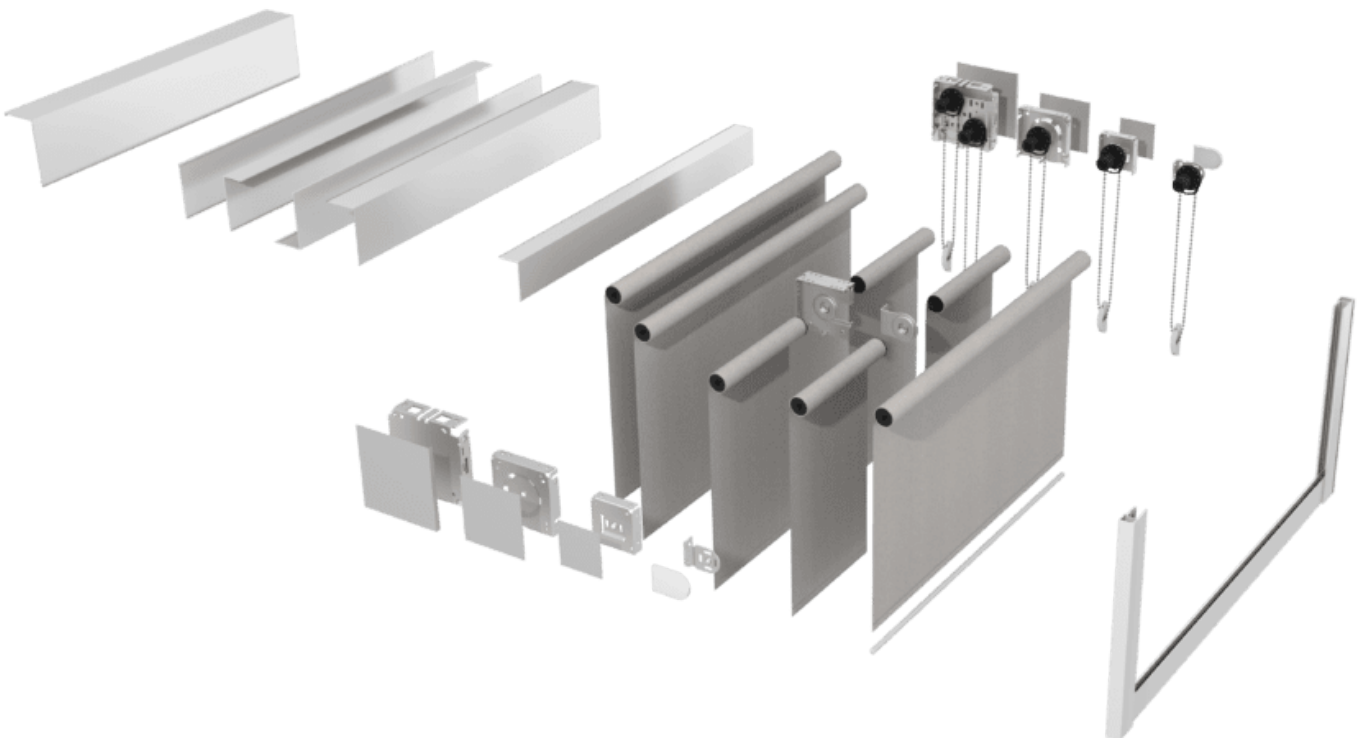

OPERABLE WALLS

FOLDING AND OPERABLE WALL PARTITIONING SYSTEMS



The DF-100 series from Cook's Construction has the ability to divide any room, from 2m to 17m - no room is too big for the DF-100S series. Incorporating 10 layers of rubber seals set in male & female profiles provides excellent sound insulation and performance. The DF-100S series boasts a top and bottom pressure seal that is manually locked into place once the wall has been opened - creating a completely secure seal from panel to panel and from the ground to ceiling track system.

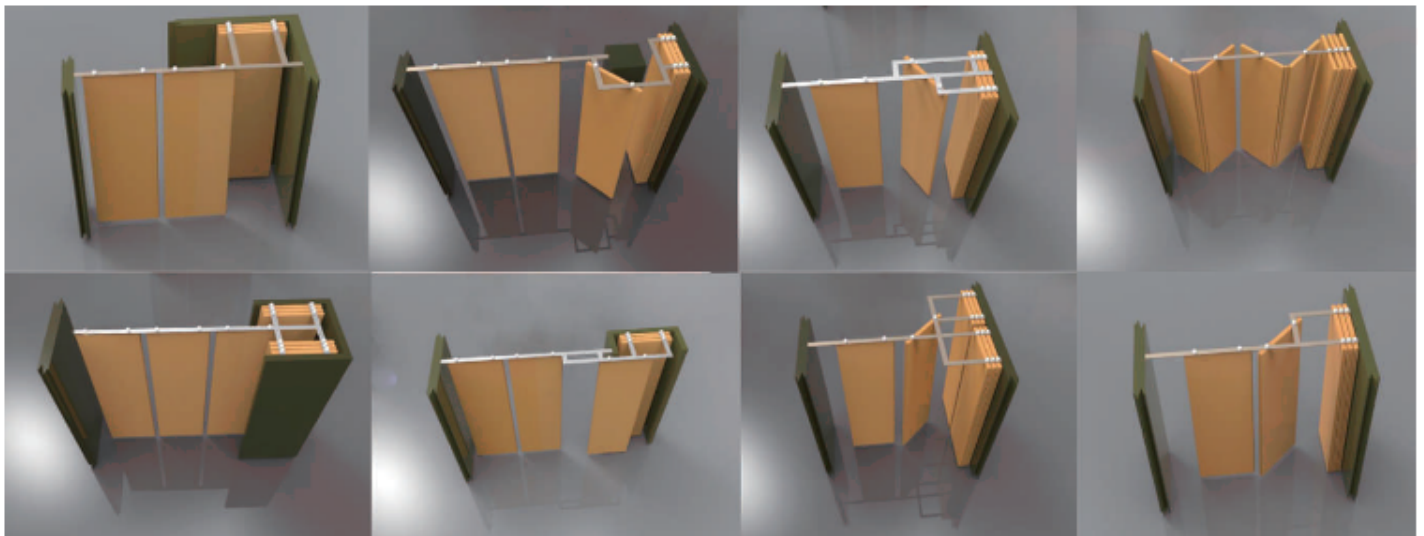

CONNECT WITH US TODAY!

Please feel free to contact us at
anytime!

Russell J. Cook, GSC, Dip.ME
russ@cooksconstruction.net
587-370-8796

John Mackenzie, P.Eng
johnm@cooksconstruction.net
236-330-6014

